

PRODUCT DATA SHEET

2024-04-17



Article number:

4005006401SSS

Braked castor 50 mm, wheel brake, TPU-tyre, all black.

Swivel bracket with wheel brake. Made of zinc-chromatized pressed sheet metal with double ball race swivel. Center hole fitting. Black laquered. Riveted wheel axle. Wheel with black TPU-tyre. Hub made of black PP. Plain bearing.



Image may differ from the actual product.*

DIMENSIONS

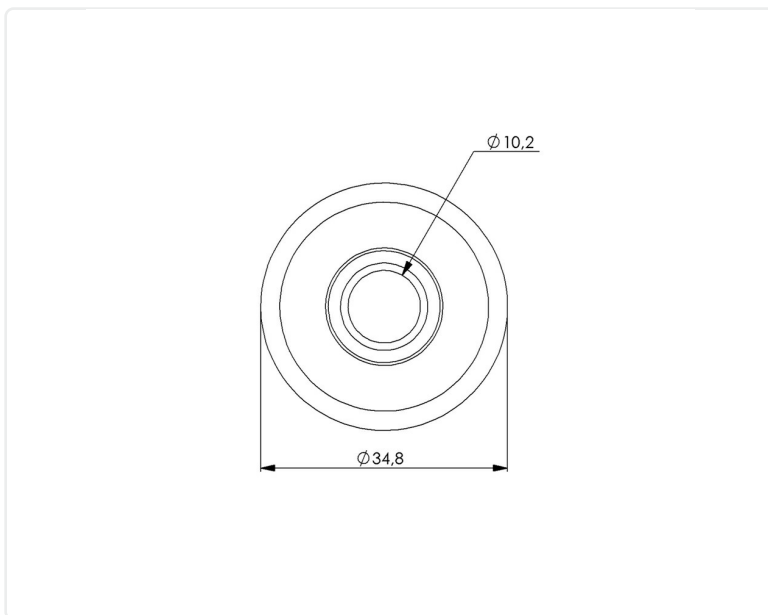

SPECIFICATIONS

Diameter	50 mm
Total height	64 mm
Load Capacity (dynamic)	40 kg
Castor model	Brake
Fitting	Centre hole
Material Tread	Polyurethane
Bearing	Rivet
Thread hardness (Shore°)	98° Shore A
Centre Bolt Hole	10.2 mm
Brake	Wheel brake
Width of tread	20 mm
Material Hub	Polypropylen (pp)
Wheel Pattern	EN 12530
Painted Housing	Black
Color Tread	Black
Material Type	RoHS (EU) - Approved
Teststandard	EN 12530
Offset	17.5 mm
Material Thickness Bracket	1.5 mm
Swivel radius	65 mm
Product Weight	0.11 kg
Temperature Range	-20°C to +50°C

Numeric values in the technical specification can be nominal/rounded to the nearest standard dimension. To see exact values, please use the drawing.